



**VELOCITYACE**

*All About Speed*





## All about Grand Tour

Velocity Ace (VA-AFO) is the newest weapon of choice for DARE and Uno-X in the upcoming Tour de France, cycling's most revered competition. In our seven years of collaboration, we've made the ranks of the WorldTour and even secured third place for the queen stage through the Alps during 2023's Tour de France! Working together towards another year of successes, we have faith that our all-new VA-AFO will take us higher and further, faster. Look for the brilliant blur of yellow hurtling forward this summer in France, and cheer us on!

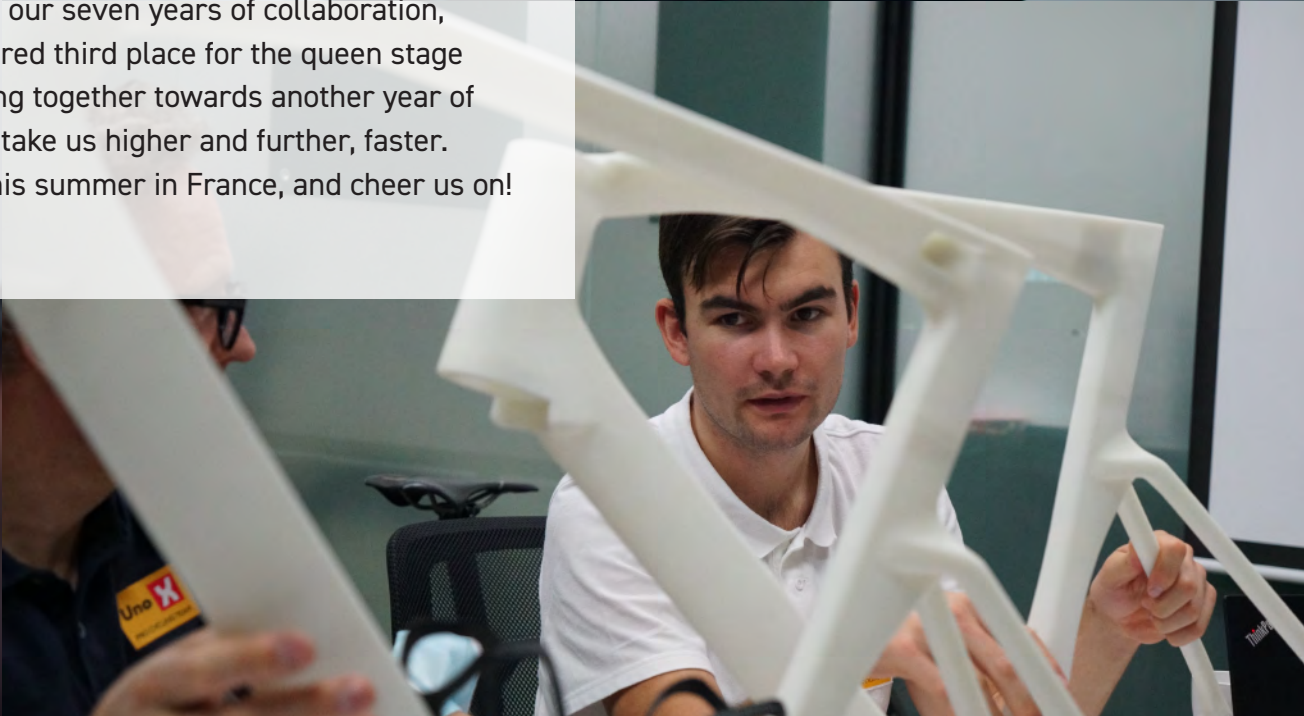

## 2024.05/06 Stage Win

- 🇫🇷 Critérium du Dauphiné (UCI 2.UWT)
- 🇧🇪 Brussels Cycling Classic (UCI 1.PRO)
- 🇳🇴 Tour of Norway (UCI 2.PRO)
- 🇧🇪 Euro Shop Elfstedenronde (UCI 1.1)
- 🇧🇪 Antwerp Port Epic (UCI 1.1)
- 🇧🇪 Heylen Vastgoed Heistse Pijl (UCI 1.1)

## 2024 Tour de France

👕 STAGE 2-4

👕 STAGE 1-11



## ***SILVER LIGHTNING*** Limited edition

In the realm of speed all movement is reduced to lines of color, a current effortlessly flowing forward and pulling you along at exhilarating velocity. Silver Swift features glimmery lines of thin silver crisscrossed with lines of red, yellow and blue traveling across its glossy silver and matte black frame, a refined display of craftsmanship.

With a limited production of 50 bikes worldwide, each bike has its own unique serial number and will definitely be a standout in your collection!

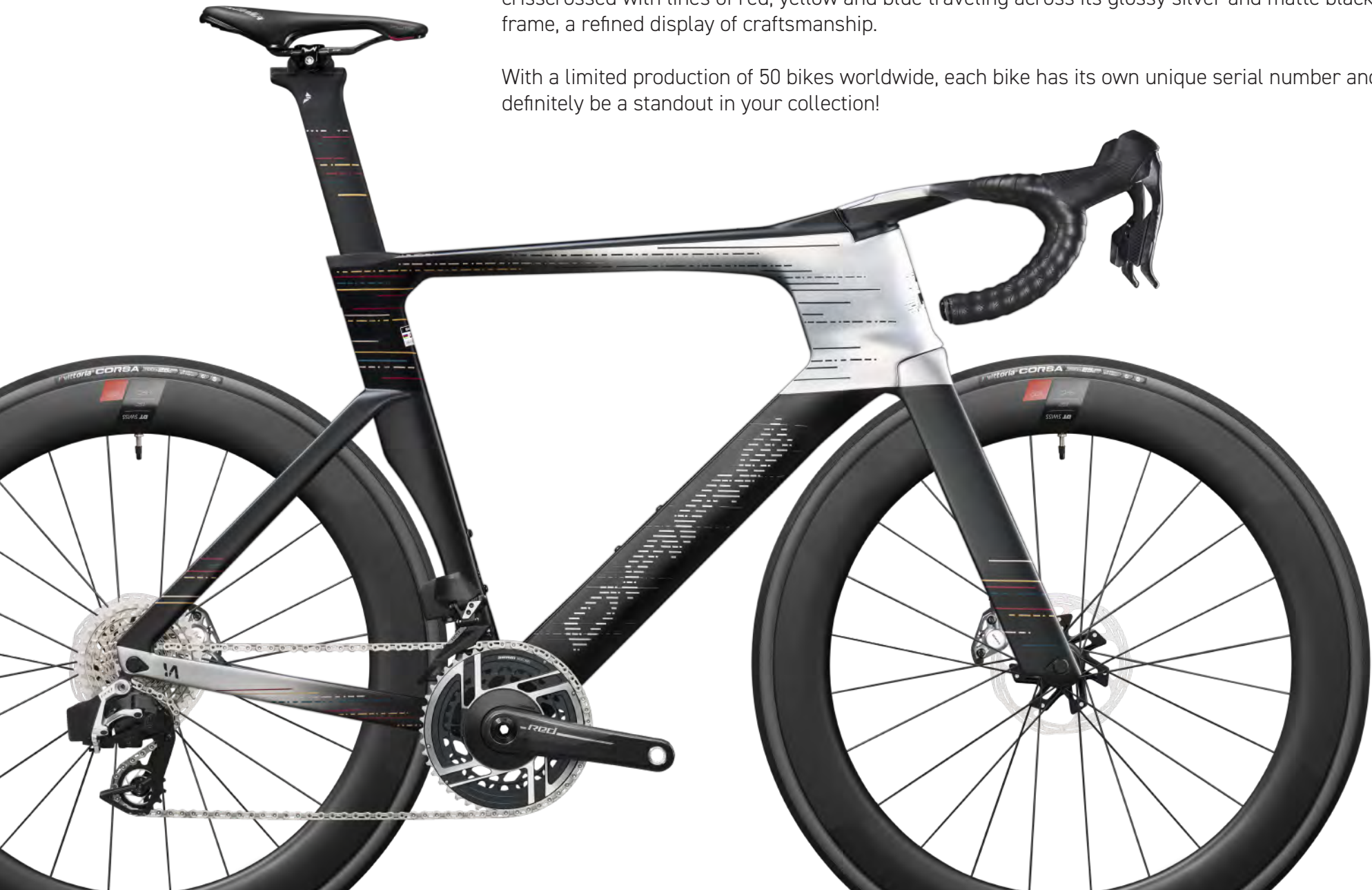



## VA-AFO SILVER LIGHTNING Spec

---

<b>Size</b>	2XS / XS / S / M / L / XL
<b>Handlebar</b>	V:C1 Torayca <sup>®</sup> Carbon aero integrated
<b>Weight</b>	Frame 1099g (M, incl. alloy parts) Fork 450g
<b>Seatpost</b>	V:P1 Torayca <sup>®</sup> Carbon aero seatpost
<b>Headset</b>	SLT by Ceramicspeed 1.5"
<b>Routing</b>	Electronic shifting, internal routing
<b>Brake</b>	Disc, max. rotor size 160mm
<b>Axle</b>	Front 10x100mm   Rear 12x142mm P1.5
<b>BB</b>	PressFit 86.5mm

## VA-AFO Geometry

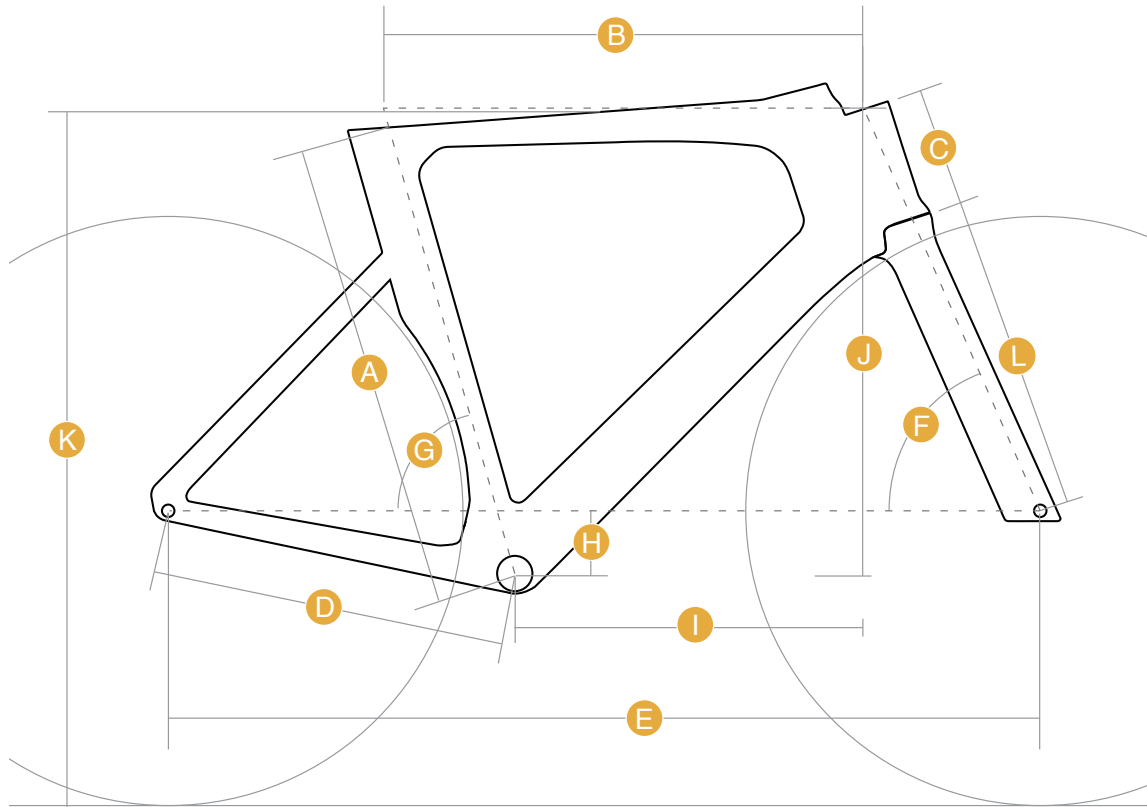

Frame size	2XS	XS	S	M	L	XL
Height(cm)	158	164	170	175	182	186
	168	174	180	185	192	200
<b>A</b> ST Length	480	500	520	540	560	580
<b>B</b> Effective TT	507	519	544	562	580	598
<b>C</b> HT length	77	96	117	138	161	181
<b>D</b> RC length	410	410	410	410	410	410
<b>E</b> Wheelbase	967	982	997	1015	1030	1048
<b>F</b> HT angle	71	71.5	72	72	72.5	72.5
<b>G</b> ST angle	74	74	74	74	74	74
<b>H</b> BB drop	75	75	73	73	70	70
<b>I</b> Reach	372	383	395	407	419	431
<b>J</b> Stack	480	500	520	541	561	580
<b>K</b> Standover	730	749	770	790	812	831
<b>L</b> Fork Length	369	369	369	369	369	369

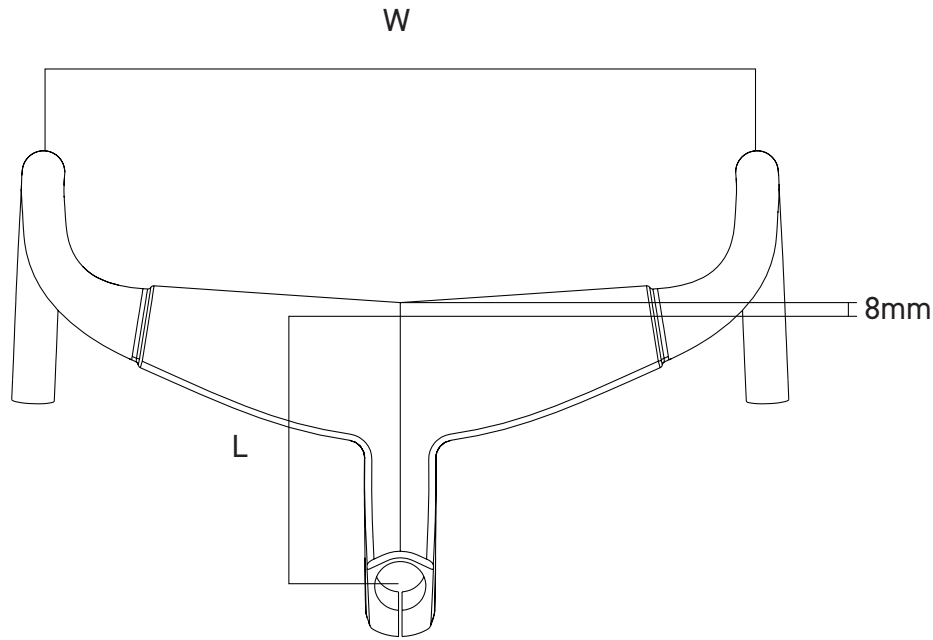

### V:C1 aero intergrade bar sizes ( L x W mm)

- 90 x 340    • 100 x 340    • 110 x 340    • 120 x 340
- 90 x 360    • 100 x 360    • 110 x 360    • 120 x 360
- 100 x 380    • 110 x 380    • 120 x 380
- 100 x 400    • 110 x 400    • 120 x 400
- 100 x 420    • 110 x 420    • 120 x 420

### VA-AFO and V:C1 Size suggestion

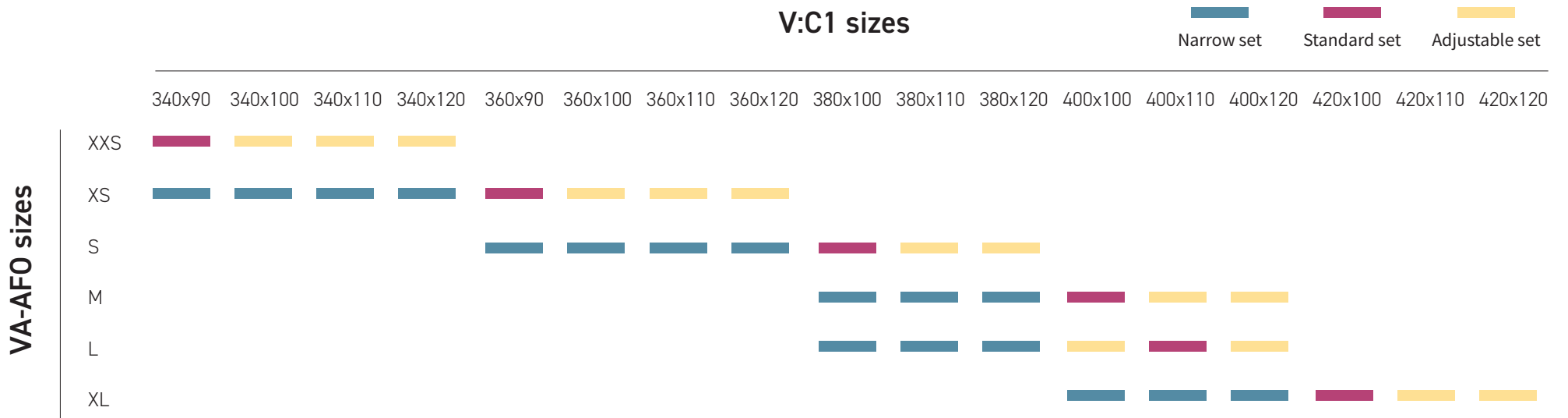

## V:C1 Geometry

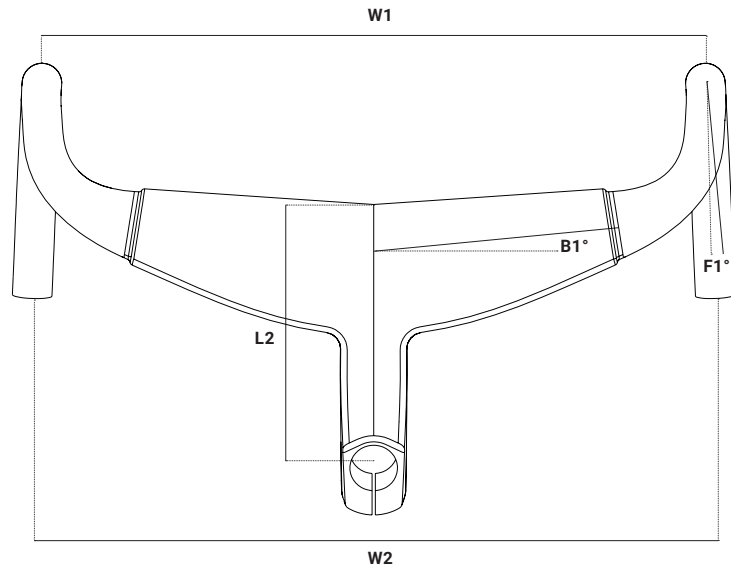

尺寸 (mm)	34	36	38	40	42
<b>W1 Hood-to-hood</b>	340	360	380	400	420
<b>W2 Drop-to-drop</b>	352	372	392	412	432
<b>R1 Reach</b>	80	80	80	80	80
<b>R2 Reach</b>	92	92	92	92	92
<b>D1 Drop</b>	133.8	133.8	133.8	133.8	133.8
<b>F1 Drop flare</b>	2	2	2	2	2
<b>B1 Backsweep</b>	-5	-5	-5	-5	-5
<b>A1 Angle</b>	-6	-6	-6	-6	-6
<b>S1 Stack</b>	33	33	33	33	33
<b>L1 Stem length*</b>	90 · 100 · 110 · 120	90 · 100 · 110 · 120	100 · 110 · 120	100 · 110 · 120	100 · 110 · 120
<b>L2 Stem length</b>	98 · 108 · 118 · 128	98 · 108 · 118 · 128	108 · 118 · 128	108 · 118 · 128	108 · 118 · 128

\*L1 Stem point-to-point length= Subtract 7mm from L2, the length between steerer bore and the front flat edge of the bar

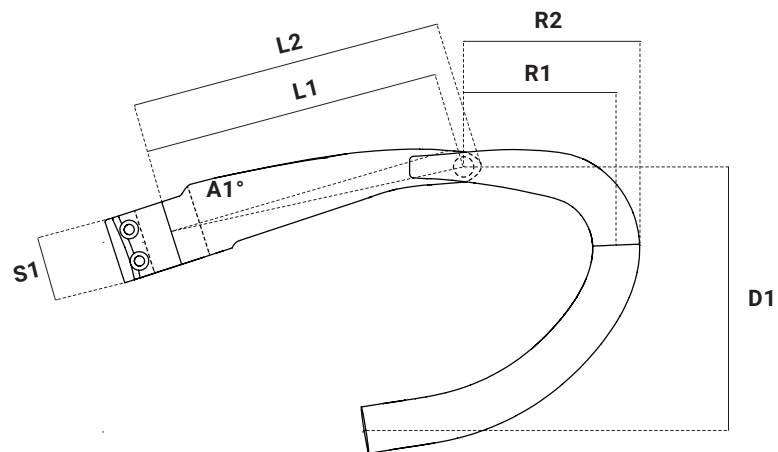

### Note:

1. This handlebar can only assembled with electronic shifting gears.
2. If you have specific fitting requirements, please pay special attention to the measurements of L1.